



# TOKISTAR LIGHTING INSTRUCTION MANUAL

## Color Mix Control System

### General Description

Tokistar's Color Mix System is for use with our LED fixtures operating at voltages from 8 to 24 VDC. With the Color Mix System, you have the ability to create any color by adjusting the brightness level of the 3-channels (Red/Green/Blue). These colors may be stored in one of the 10 memory locations. In the animation mode, the colors can be set in motion. You can flash, fade or cross fade between selected colors, or select our Demo Mode which is a dynamic combination of all three.

**There are three basic components to the control system. These include:**

#### 1.) The Color Mix Logic Controller.

This is the remote wall station from where you control the lighting effects. It communicates the signal to the Dimmer Packs via a CAT 5 cable (supplied).

#### 2.) Dimmer Packs

Dimmer Packs accept the control signal from the logic controller, and an 8 or 24 VDC input from the LED Driver. They send a 0-8 or 0-24 VDC output to the lighting fixtures.

#### 3.) LED Drivers

These devices convert an input AC Voltage (from 100 to 240 VAC) into a DC output (8 or 24 VDC depending on the model). The output is connected to the Dimmer Packs.

Before beginning the installation, familiarize yourself with the System Overview below and the component features on the following pages.

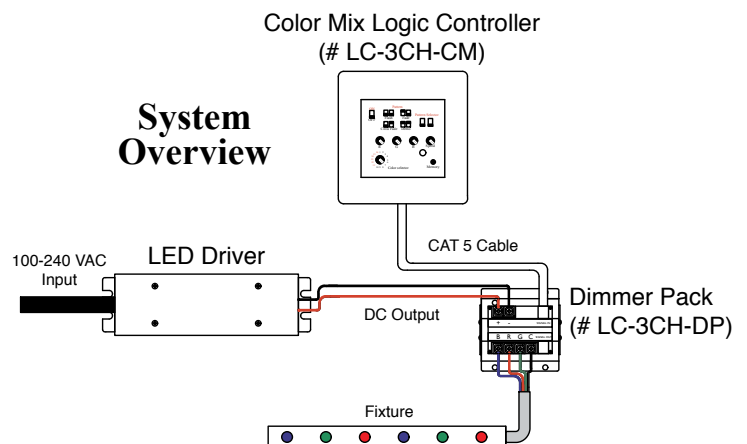

### PRECAUTIONS

1. Read all instructions completely before beginning installation.
2. Turn off electricity before beginning installation.
3. All wiring is to be performed by a qualified electrician.
4. Installation must comply with the National Electrical Code, and all applicable codes.
5. Turn main supply to LED Driver on only after all connections have been made and tested.
6. Use only LED Drivers provided by Tokistar with the system.

### TOKISTAR® LIGHTING

1015 E. Discovery Lane  
Anaheim, CA 92801

TEL: 714 772 7005 FAX: 714 772 7014  
email: info@tokistar.com Website: tokistar.com

## 1.) - Color Mix Logic Controller

### Part#: LC-3CH-CM

This wall station can be placed at a convenient location, remote from the first Dimmer Pack. The Logic Controller receives its operating voltage from the first Dimmer Pack with the CAT 5 cable provided.

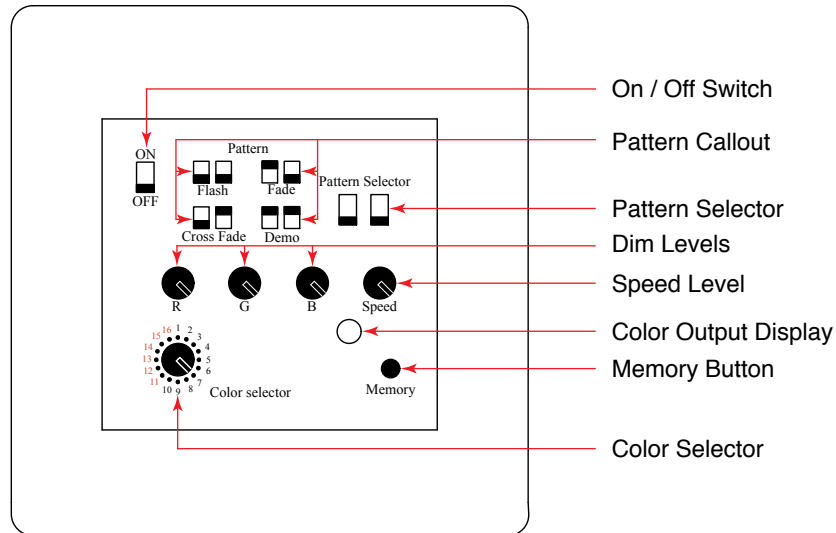

### Fixed Colors

Channels 1-10 on the Color Selector switch store ten colors. These are shipped pre-programmed by the factory, but new colors can be selected and assigned to each location (see storing new colors). Below is a list of these ten preset colors and their respective locations.

### Pattern Selection

The Logic Controller has four operating modes which can be changed by toggling the positions of the Pattern Selector switches. These modes are:

- 1.) Flash - Distinct sequencing from color to color.
- 2.) Fade - Colors fade in and out from 0-100% brightness level.
- 3.) Cross Fade - One color fades out as the next color fades in, creating attractive color blends between the two.
- 4.) Demo Mode - A combination of the 3 modes above, cycling through all colors.

### Dynamic Animation

- Channels 11-16 on the color selector sequence through different color combinations.
- Channels 11, 12, & 13 cycle through color combinations which are not influenced by any changes in memory settings.
- Channels 14, 15 & 16 cycle through color combinations based upon settings stored in memory. Channel 14 cycles colors 1-4, Channel 15 cycles colors 1-7, and Channel 16 cycles colors 1-10.

Channel	1	2	3	4	5	6	7	8	9	10	11	12	13	14	15	16
	R	G	B	C	M	Y	W	R	G	B	R G B	C M Y	R G B C M Y W	1-4	1-7	1-10
	RED	GREEN	BLUE	CYAN	MAGENTA	YELLOW	WHITE	RED	GREEN	BLUE	R G B	C M Y	R G B C M Y W			
	FIXED COLOR (Color Setting Available)										DYNAMIC COLOR			DYNAMIC COLOR		
											*1			*2		

\*1 Not influenced by Fixed Color (1-10)  
 \*2 Influenced by Fixed Color (1-10)

## Color Mix Controller (continued)

### Storing New Colors

- 1.) Set the color selector switch to any position from 1-10.
- 2.) Push the memory button (LED indicator blinks green).
- 3.) Create color by selecting the brightness levels on the R G B (Red, Green and Blue) dials.
- 4.) Push and hold the memory button for two seconds (LED indicator blinks blue).
- 5.) If you want to cancel storing a new color, press and hold the memory button again until the LED indicator blinks red.

### Speed Selection

Turn the dial to increase / decrease rate of color changing in Dynamic Animation modes.

## 2.) - Dimmer Packs

### Part#: LC-3CH-DP

Each Dimmer Pack operating from our LDR8-40 or LDR8-80 has a maximum capacity of 40 watts @ 8 VDC.

Each Dimmer Pack operating from our LDR24-96 LED Driver has a maximum capacity of 96 watts @ 24 VDC.

Each Dimmer Pack operating from our LDR24-120 LED Driver has a maximum capacity of 100 watts @ 24 VDC.

The DC input is provided from one of our LED drivers and connected to the + / - terminals. The DC output to the lighting fixtures is connected to terminals marked B (Blue Channel), R (Red Channel), G (Green Channel) and C (Common Wire).

The first Dimmer Pack requires a logic input from the Color Mixer Logic Controller via a CAT 5 cable (supplied with Color Mixer). If multiple Dimmer Packs are used, they are linked with additional CAT 5 cables (also supplied). A maximum number of 25 Dimmer Packs can be connected in series if the total length of all CAT5 cable does not exceed 165 ft. (50 M) from the controller to the last dimmer pack.

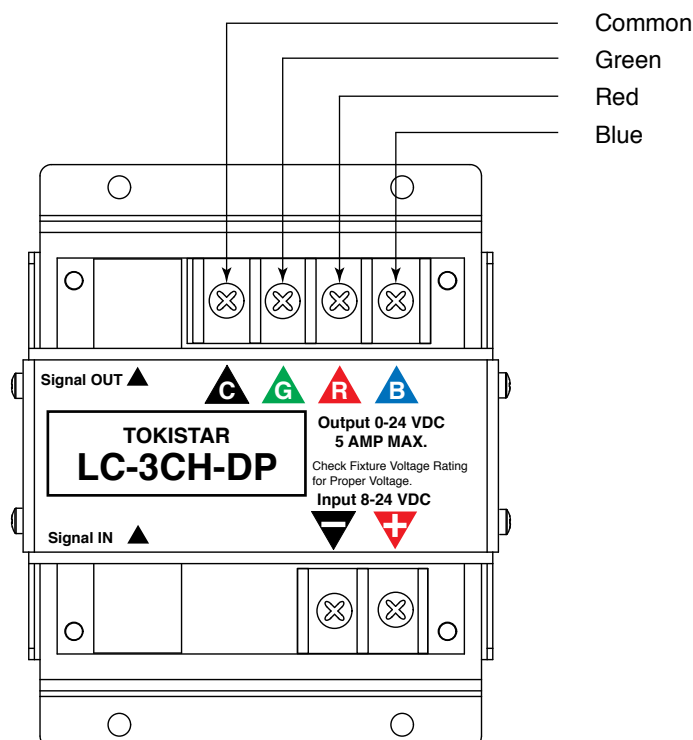

## 3.) - LED Drivers

**Part#s: LDR8-40, LDR8-80, LDR24-96, LDR24-120**

Refer to the installation instructions supplied with the LED Drivers.

## Installation Instructions

**Step 1** - Install lighting fixtures to surface using secure means.

**Step 2** - Route secondary wires from lighting fixtures to Dimmer Pack location. If additional wire is required, maintain color code of wires.

**Step 3** - Install Dimmer Pack and attach lead wires from lighting fixtures to terminals on Dimmer Pack in accordance with wiring diagram.

**Step 4** - Install LED Drivers next to Dimmer Packs and connect secondary DC outputs to Dimmer Pack terminals in accordance with wiring diagram. Be sure to maintain proper polarity.

**Step 5** - Install Color Mix Logic Controller at convenient remote location. Keep ON / OFF switch in OFF position.

**Step 6** - Connect CAT 5 logic cable from Color Mix Controller to first dimmer pack (supplied with Controller).

**Step 7** - Connect CAT 5 logic cables between Dimmer Packs (supplied with each Dimmer Pack). A maximum number of 25 Dimmer Packs can be connected in series if the total length of all CAT5 cable does not exceed 165 ft. (50 M) from the controller to the last dimmer pack.

**Step 8** - With Power OFF, wire primary inputs to each LED Driver.

**Step 9** - Turn Power ON to LED Drivers.

**Step 10**- Turn switch to ON position on Color Mix Controller.

## PRECAUTION

All dimming components are rated for dry location only. They must be installed within an enclosure suitable for the environment.

## TOKISTAR® LIGHTING

1015 E. Discovery Lane

Anaheim, CA 92801

TEL: 714 772 7005 FAX: 714 772 7014

email: info@tokistar.com Website: tokistar.com